

# SANCH

## SE Series User Manual

---

220V 200W-2HP

Simple General Purpose AC Drive



**ASIA**

**SANCH ELECTRIC CO.,LTD.**

**Sales Office/**

LUO JIANG INDUSTRIAL ZONE

ZHUANGREN 2#, CHINA

TEL:886-595-2670315

FAX:886-595-2670319

Http://www.sanch.net

## Preface

Thank you for choosing SANCH's SE series AC Drive. The SE series is manufactured using high-quality components, material and incorporating the latest microprocessor technology available.

This manual will help in the installation, parameter setting, troubleshooting, and daily maintenance of the AC motor drive. To guarantee safe operation of the equipment, read the following safety guidelines before connecting power to the AC motor drive. Keep this operating manual handy and distribute to all users for reference.

### Important Notes:

**DANGER!** AC input power must be disconnected before any maintenance. Do not connect or disconnect wires while power is applied to the circuit. Only qualified technicians should perform maintenance on the SE.

**CAUTION!** There are highly sensitive MOS components on the printed circuit boards. These components are especially sensitive to static electricity. To avoid damaging these components, do not touch the circuit boards with metal objects or your bare hands.

**DANGER!** A charge may still remain in the DC-link capacitor with hazardous voltages even after the power has been turned off. To avoid personal injury, do not remove the cover of the AC drive until all "DISPLAY LED" lights on the digital keypad are off. Please note that there are live components exposed when the AC drive is open,. Be careful to not touch these live parts.

**CAUTION!** Ground the SE using the ground terminal.  The grounding method must comply with the laws of the country where the AC drive is to be installed.

**DANGER!** The AC drive may be destroyed beyond repair if power is misapplied to the input/output terminals. Never connect the AC drive output terminals U/T1, V/T2, W/T3 directly to the AC main circuit power supply.

# Chapter 1 Receiving and Inspection

This SE AC drive has gone through rigorous quality control tests at the factory before shipment. Since many things may happen during shipping, please check for the following after receiving the AC motor drive.

Inspect the unit to insure it was not damaged during shipment.

Make sure that the part number indicated on the nameplate corresponds with the part number of your order.

**Nameplate Information:** Example of 1HP 220V

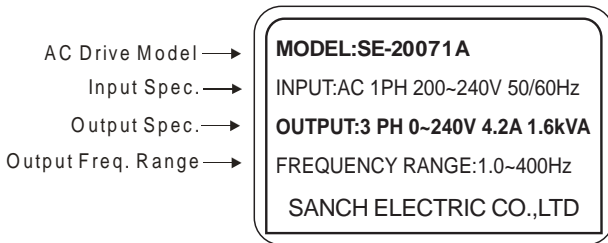

**Model Explanation:**

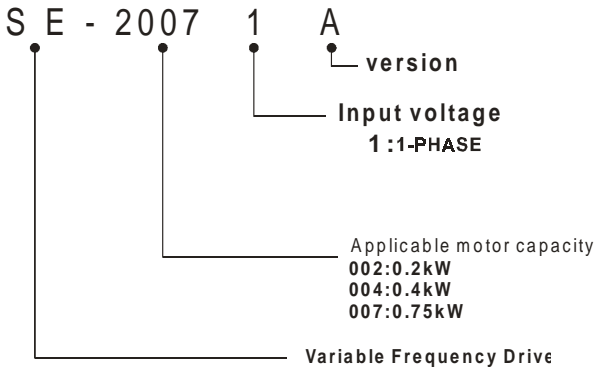

## Dimension

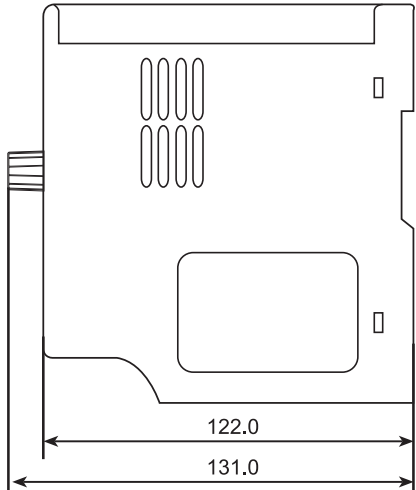
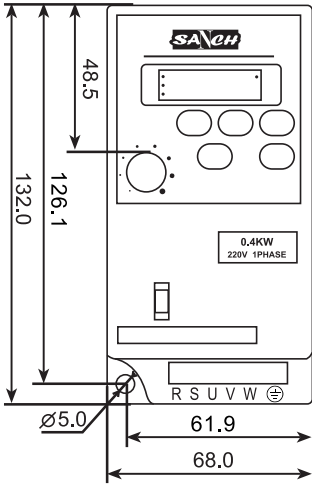

## Chapter 2 Wiring

### Basic Wiring Diagram

Users must connect wiring according to the circuit diagram shown below. Please follow all National and State wiring codes, when wiring the SE.

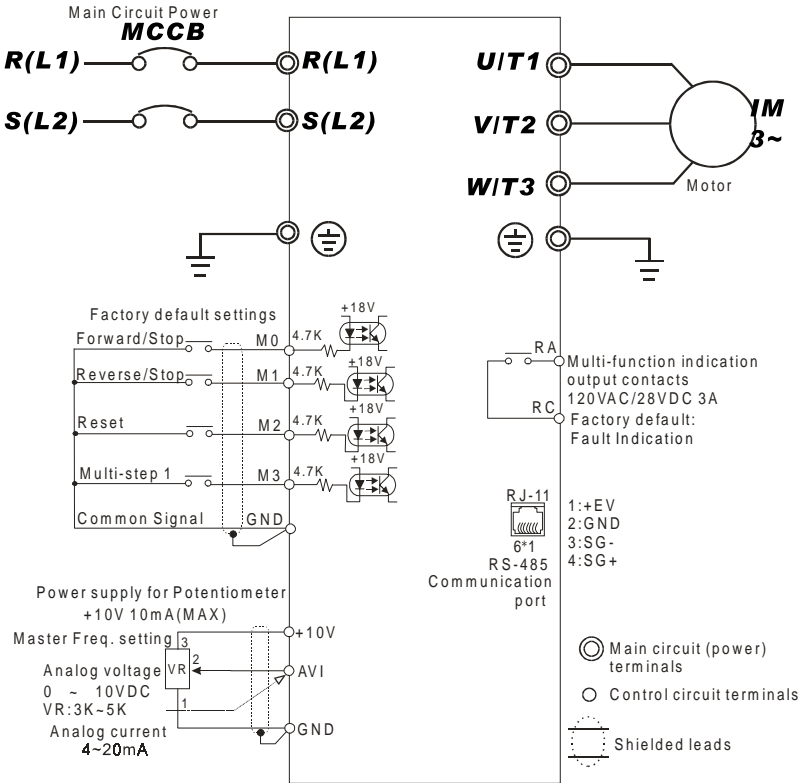

**NOTE:** Do not plug in a Modem or telephone line to the RS-485 communication port, permanent damage may result. Terminals 1 & 2 are the power source for the optional copy keypad and should not be used while using RS-485 communication.

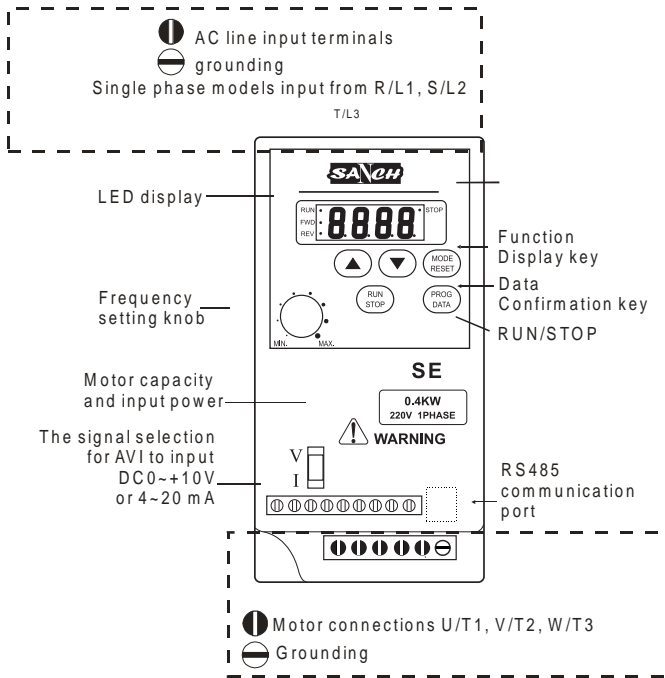

## Main circuit wiring

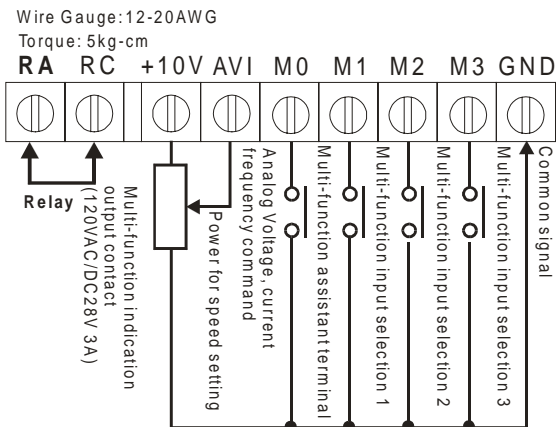

## Control circuit wiring



## Wiring Notes: PLEASE READ PRIOR TO INSTALLATION.

1.  **CAUTION:** Do not connect the AC input to any of the U/T1, V/T2, W/T3 terminals, as it will damage the AC drive.
2.  **WARNING:** Ensure all screws are tightened to the proper torque rating.
3. During installation, follow all national and local electrical, construction, and safety codes for the country the drive is to be installed in.
4. Ensure the appropriate protective devices (circuit breaker or fuses) are connected between the power supply and AC drive.
5. Make sure that the leads are connected correctly and the AC drive is properly grounded. (Ground resistance should not exceed 0.1.)
6. Use ground leads that comply with AWG/MCM standards and keep them as short as possible.
7. Multiple SE units can be installed in one location. All the units should be grounded directly to a common ground terminal. The SE ground terminals may also be connected in parallel, as shown in the figure below. **Ensure there are no ground loops.**

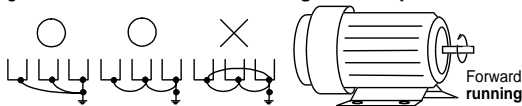

When the AC drive output terminals U/T1, V/T2, and W/T3 are connected to the motor terminals U, V, and W, respectively, the motor will rotate counterclockwise (as viewed from the shaft ends of the motor) when a forward operation command is received. To reverse the direction of motor rotation, switch over any of the two motor leads.

9. Make sure that the power is capable of supplying the correct voltage and required current to the AC drive.
10. Do not attach or remove wiring when power is applied to the AC drive.
11. Do not monitor the signals on the circuit board while the AC drive is in operation.
12. Route the power and control wires separately, or orthogonal to each other.
13. If a filter is required for reducing EMI (Electro-Magnetic Interference), install it as close as possible to AC drive. EMI can also be reduced by lowering the Carrier Frequency.
14. If the AC drive is installed in the place where a load reactor is needed, install the filter close to U/T1, V/T2, W/T3 side of AC drive. Do not use a Capacitor or L-C Filter (Inductance-Capacitance) or R-C Filter (Resistance-Capacitance).
15. When using a GFCI (Ground Fault Circuit Interrupt), select a current sensor with minimum current 200mA, and minimum detection time 0.1-second to avoid nuisance tripping.

## Chapter 3 Summary of Parameters

### Group 0: User Parameters

The parameter may be set during operation.

|   | Parameter | Functions                             | Settings  | Factor Setting |
|---|-----------|---------------------------------------|---|----------------|
|   | 0-00      | Identity code of drive<br>(Read only) | 3: 200W<br>4: 400W<br>5: 750W   |                |
|   | 0-01      | Rated current display<br>(Read only)  | 200W: 1.6A<br>400W: 2.5A<br>750W: 4.2A  |                |
|   | 0-02      | Parameter reset                       | 10: Reset Parameters to Factory Setting   | 0              |
| ✓ | 0-03      | Start-up display of AC<br>drive       | 0: F (Frequency command)<br>1: H (output frequency)<br>2: U (user-defined unit)<br>3: A (output current)  | 0              |
| ✓ | 0-04      | User-defined Unit                     | 0: Display User-Defined Unit (u)<br>1: Display Counter Value (C)<br>2: Display Process Operation (1=tt)<br>3: Display DC-BUS voltage (U)<br>4: Display output voltage (E) | 0              |
| ✓ | 0-05      | User-defined coefficient              | 0.1 ~ 160   | 1.0            |
|   | 0-06      | Software version                      | Read only   | #. #           |
|   | 0-07      | Password input                        | 0 ~ 999   | 0              |
|   | 0-08      | Password configuration                | 0 ~ 999   | 0              |

### Group 1: Basic Parameters

|   | Parameter | Functions              | Settings      | Factor Setting |
|---|-----------|------------------------|---------------|----------------|
|   | 1-00      | Maximum operation Freq | 50.0 ~ 400Hz  | 60.0           |
|   | 1-01      | Maximum setting Freq.  | 10.0 ~ 400Hz  | 60.0           |
|   | 1-02      | Maximum output voltage | 2.0 ~ 255V    | 220            |
|   | 1-03      | Mid-point freq.        | 1.0 ~ 400Hz   | 1.0            |
|   | 1-04      | Mid-point voltage      | 2.0 ~ 255V    | 12.0           |
|   | 1-05      | Minimum output freq.   | 1.0 ~ 60.0Hz  | 1.0            |
|   | 1-06      | Minimum output voltage | 2.0 ~ 255V    | 12.0           |
|   | 1-07      | Upper bound of freq.   | 1 ~ 110%      | 100            |
|   | 1-08      | Lower bound of freq.   | 0 ~ 100%      | 0.0            |
| ✓ | 1-09      | Accel time 1 (Tacc1)   | 0.1 ~ 600 Sec | 10.0           |
| ✓ | 1-10      | Decel time 1 (Tdec1)   | 0.1 ~ 600 Sec | 10.0           |
| ✓ | 1-11      | Accel time 2           | 0.1 ~ 600 Sec | 10.0           |

|   | Parameter | Functions                       | Settings   | Factor Setting |
|---|-----------|---------------------------------|--|----------------|
| ↗ | 1-12      | Decel time 2                    | 0.1 ~ 600 Sec  | 10.0           |
| ↗ | 1-13      | JOG Accel time                  | 0.1 ~ 600 Sec  | 10.0           |
| ↗ | 1-14      | JOG Decel time                  | 0.0 ~ 600 Sec  | 10.0           |
| ↗ | 1-15      | JOG frequency                   | 1.0Hz~400Hz  | 6.0            |
|   | 1-16      | Auto-accel/decel                | 0: Linear Accel/Decel<br>1: Auto accel, linear decel<br>2: Linear accel, auto decel,<br>3: Auto Accel/Decel<br>4: Linear accel. Auto decel, stall preventio<br>during deceleration<br>5: Auto accel. Auto decel, stall prevention<br>during deceleration | 0              |
|   | 1-17      | S-curve setting in acceleration | 0 ~ 7  | 0              |
|   | 1-18      | S-curve setting in deceleration | 0 ~ 7  | 0              |

### Group 2: Operation Method Parameters

|  | aramete | Functions                           | Settings   | Factor Setting |
|--|---------|-------------------------------------|--|----------------|
|  | 2-00    | Source of frequency command         | 0: Digital keypad<br>1: 0 ~ 10V from AVI<br>2: 4 ~ 20mA from AVI<br>3: Controlled by V.R on drive<br>4: RS-485 communication interface   | 0              |
|  | 2-01    | Source of operation command         | 0: By digital keypad<br>1: By external terminals, keypad STOP enable<br>2: By external terminals, keypad STOP disable<br>3: By RS-485 communication interface, keypad STOP enable<br>4: By RS-485 communication interface, keypad STOP disable | 0              |
|  | 2-02    | Stop method                         | 0: Ramp stop<br>1: Coast stop  | 0              |
|  | 2-03    | Carrier freq.                       | 3 ~10k Hz  | 10             |
|  | 2-04    | Reverse operation inhibit           | 0: Enable reverse<br>1: Disable reverse<br>2: Disable forward  | 0              |
|  | 2-05    | ACI (4 ~ 20mA) input loss detection | 0: Decel to 0Hz<br>1: Stop immediately, display EF<br>2: Run with the last freq.   | 0              |
|  | 2-06    | Line Start Lockout                  | 0: Enable<br>1: Disable  | 0              |

### Group 3: Output Function Parameters

| Parameter | Functions                     | Settings  | acto<br>Settin |
|-----------|-------------------------------|---|----------------|
| 3-00      | Desired freq. attained        | 1.0 ~ 400 Hz  | 1.0            |
| 3-01      | Terminal count value          | 0~ 999  | 0              |
| 3-02      | Preliminary count value       | 0~ 999  | 0              |
| 3-03      | Multi-function (relay output) | 0: not used<br>1: AC drive operational<br>2: Max. Output Freq. Attained<br>3: Zero Speed<br>4: Over Torque<br>5: Base-Block (B.B.)<br>6: Low Voltage Detection<br>7: AC Drive Operation Mode<br>8: Fault Indication<br>9: Desired Freq. Attained<br>10: PLC Program Running<br>11: PLC Program Step Complete<br>12: PLC Program Complete<br>13: PLC Program Operation Pause<br>14: Terminal Count Value Attained<br>15: Preliminary Count Value Attained<br>16: Ready State Indicator | 8              |

### Group 4: Input Function Parameters

| Parameter | Functions   | Settings  | Factor<br>setting |
|-----------|---|---|-------------------|
| ↗ 4-00    | Potentiometer bias freq.                              | 0.0 ~ 350Hz   | 0.0               |
| ↗ 4-01    | Potentiometer bias polarity                           | 0: positive bias 1: negative bias   | 0                 |
| ↗ 4-02    | Potentiometer freq. gain                              | 1 ~ 200%  | 100               |
| 4-03      | Potentiometer reverse motion enable                   | 0: not used<br>1: reverse motion enable<br>2: forward motion only   | 0                 |
| 4-04      | Multi-function input terminal1 (M1) (d 0 ~ d 20)      | 0: not used<br>1: M0: FWD/STOP, M1: REV/STOP<br>2: M0: RUN/STOP, M1: FWD/REV  | 1                 |
| 4-05      | Multi-function input terminal 2(M2)                   | 3: M0, M1, M2: 3-wire operation control mode<br>4: External fault, normally open (N.O.)   | 6                 |
| 4-06      | Multi-function input terminal 3(M3) (d 0, d 4 ~ d 20) | 5: External fault, normally closed (N.C.)<br>6: RESET<br>7: multi-step speed command 1<br>8: multi-step speed command 2<br>9: jog operation<br>10: accel/decel speed inhibit<br>11: first or second accel/decel time selection<br>12: base-block (B.B.),normally open (N.O.)<br>13: base-block (B.B.),normally closed (N.C) | 7                 |

| Parameter | Functions  | Settings   | Factor setting |
|-----------|--|--|----------------|
| 4-06      | Multi-function input terminal 3(M3)<br>(d 0, d 4 ~ d 20) | 14: increase master freq.<br>15: decrease master freq.<br>16: run PLC program<br>17: pause PLC<br>18: counter trigger signal<br>19: counter reset<br>20: select ACI/deselect AVI | 7              |

#### Group 5: Multi-step Speed and PLC Parameters

| Parameter | Functions                        | Settings  | actio Settlin |
|-----------|----------------------------------|---|---------------|
| 5-00      | 1 <sup>st</sup> step speed freq. | 0.0 ~ 400Hz   | 0.0           |
| 5-01      | 2 <sup>nd</sup> step speed freq. | 0.0 ~ 400Hz   | 0.0           |
| 5-02      | 3 <sup>rd</sup> step speed freq. | 0.0 ~ 400Hz   | 0.0           |
| 5-03      | PLC mode                         | 0: Disable PLC operation<br>1: Execute one program cycle<br>2: Continuously execute program cycles<br>3: Execute one program cycle step by step (separate by STOP)<br>4: Continuously execute one program cycle step by step (separate by STOP) | 0             |
| 5-04      | PLC forward/revers motion        | 0 ~ 15 (0: Forward 1: Reverse)  | 0             |
| 5-05      | Time duration step               | 0 ~ 65500 Sec   | 0             |
| 5-06      | Time duration step               | 0 ~ 65500 Sec   | 0             |
| 5-07      | Time duration step               | 0 ~ 65500 Sec   | 0             |
| 5-08      | Time duration step               | 0 ~ 65500 Sec   | 0             |

#### Group 6: Protection Parameters

| Parameter | Functions                     | Settings   | actio Settlin |
|-----------|-------------------------------|--|---------------|
| 6-00      | Over-Voltage Prevention Level | 0:disable<br>350~410V  | 390           |
| 6-01      | Over-current Prevention Level | 0: disable<br>20~200%  | 170           |
| 6-02      | Over-torque detection         | 0:disable<br>1:enable during constant speed operation(oL2) and continues until the continuous limit is reached.<br>2:enable during constant speed operation(oL2) and halted after detection.<br>3:enabled during accel and continues before continuous output time limit is reached.<br>4:enabled during accel and halted after over-torque detection. | 0             |
| 6-03      | Over-torque detection level   | 30 ~ 200%  | 150           |

|  | Parameter | Functions                         | Settings  | act<br>Settin |
|--|-----------|-----------------------------------|---|---------------|
|  | 6-04      | Over-torque detection time        | 0.1 ~ 10.0 Sec  | 0.1           |
|  | 6-05      | Electronic thermal overload relay | 0: Not used<br>1: Act with standard motor<br>2: Act with special motor  | 0             |
|  | 6-06      | Electronic thermal characteristic | 30~600 Sec  | 60            |
|  | 6-07      | Present fault recor               | 0: No fault occurred  | 0             |
|  | 6-08      | Second most rece fault record     | 1: oc (over current)<br>2: ov (over voltage)  |               |
|  | 6-09      | Third most recent fault record    | 3: oH (over heat)<br>4: oL (over load)  |               |
|  | 6-10      | Forth most recent fault record    | 5: oL1 (electronic thermal)<br>6: EF (external fault)   |               |
|  | 6-11      | Fifth most recent fault record    | 7: Reserved<br>8: Reserved  |               |
|  | 6-12      | Sixth most recent fault record    | 9: ocA (current exceed during acceleration)<br>10: ocd (current exceed during deceleration)<br>11: ocn (current exceed during steady state) |               |

#### Group 7: Motor Parameters

|   | aramete | Functions           | Settings   | Factory Setting |
|---|---------|---------------------|------------|-----------------|
| ✓ | 7-00    | Motor rated current | 30~120 %   | 85              |
| ✓ | 7-01    | Motor no-load curre | 0 ~ 90 %   | 50              |
| ✓ | 7-02    | Torque compensation | 0 ~ 10     | 1               |
| ✓ | 7-03    | Slip compensation   | 0.0 ~ 10.0 | 0.0             |

#### Group 8: Special Parameters

|  | Parameter | Functions                       | Settings   | Factory Setting |
|--|-----------|---------------------------------|--|-----------------|
|  | 8-00      | DC braking voltage level        | 0 ~ 30%  | 0               |
|  | 8-01      | DC braking time during start-up | 0.0 ~ 60.0 Sec   | 0.0             |
|  | 8-02      | DC braking time during stopping | 0.0 ~ 60.0 Sec   | 0.0             |
|  | 8-03      | Start-point for DC braking      | 0.0 ~ 400.0 Sec  | 0.0             |
|  | 8-04      | Momentary power loss            | 0: Stop operation after momentary power loss.<br>1: Continues after momentary power loss speed search starts with master freq.<br>2: Continues after momentary power loss speed search starts with min. output freq. | 0               |

|  | Parameter | Functions                       | Settings  | Factory Setting |
|--|-----------|---------------------------------|---|-----------------|
|  | 8-05      | Max. allowable power loss time  | 0.3 ~ 5.0 Sec   | 2.0             |
|  | 8-06      | B.B. time for speed search      | 0.3~5.0 Sec   | 0.5             |
|  | 8-07      | Max. speed search current level | 30~200%   | 150             |
|  | 8-08      | Skip freq. 1 upper bound        | 0.0~400 Hz  | 0.0             |
|  | 8-09      | Skip freq. 1 lower bound        | 0.0~400 Hz  | 0.0             |
|  | 8-10      | Skip freq. 2 upper bound        | 0.0~400 Hz  | 0.0             |
|  | 8-11      | Skip freq. 2 lower bound        | 0.0~400 Hz  | 0.0             |
|  | 8-12      | Skip freq. 3 upper bound        | 0.0~400 Hz  | 0.0             |
|  | 8-13      | Skip freq. 3 lower bound        | 0.0~400 Hz  | 0.0             |
|  | 8-14      | Auto restart after fault        | 0~10  | 0               |
|  | 8-15      | AVR function                    | 0: AVR function enable<br>1: AVR function disable<br>2: AVR function disable when decel | 2               |
|  | 8-16      | dynamic braking voltage         | 350 ~ 450V  | 380             |
|  | 8-17      | C braking lower bound limit     | 0.0 ~ 400 Hz  | 0.0             |

#### Group 9: Communication Parameters

|         | Parameter  | Functions                           | Settings  | Factor Setting |  |         |                                  |   |
|---------|--|-------------------------------------|---|----------------|--|---------|----------------------------------|---|
| ↗       | 9-00   | Communication address               | 1 ~ 247   | 1              |  |         |                                  |   |
| ↗       | 9-01   | Transmission speed                  | 0: Baud rate 4800<br>1: Baud rate 9600<br>2: Baud rate 19200  | 1              |  |         |                                  |   |
| ↗       | 9-02   | Transmission fault treatment        | 0: Warn and continue running<br>1: Warn and ramp to stop<br>2: Warn and coasting stop<br>3: No warn and keep running  | 0              |  |         |                                  |   |
| ↗       | 9-03   | Modbus communication watchdog timer | 0: Disable<br>1~20: 1 ~ 20 Sec  | 0              |  |         |                                  |   |
| ↗       | 9-04   | Communication protocol              | <table border="1"> <tbody> <tr> <td>ASC mod</td> <td>0: 7,N,2<br/>1: 7,E,1<br/>2: 7,O,1<br/>3: 8,N,2<br/>4: 8,E,1<br/>5: 8,O,1</td> </tr> <tr> <td>RTU mod</td> <td>6: 8,N,2<br/>7: 8,E,1<br/>8: 8,O,1</td> </tr> </tbody> </table> | ASC mod        | 0: 7,N,2<br>1: 7,E,1<br>2: 7,O,1<br>3: 8,N,2<br>4: 8,E,1<br>5: 8,O,1 | RTU mod | 6: 8,N,2<br>7: 8,E,1<br>8: 8,O,1 | 0 |
| ASC mod | 0: 7,N,2<br>1: 7,E,1<br>2: 7,O,1<br>3: 8,N,2<br>4: 8,E,1<br>5: 8,O,1 |                                     |   |                |  |         |                                  |   |
| RTU mod | 6: 8,N,2<br>7: 8,E,1<br>8: 8,O,1                                     |                                     |   |                |  |         |                                  |   |

## CHAPTER 4 Troubleshooting and Fault Information

The SE AC drive has a comprehensive fault diagnostic system that includes several different alarms and fault messages. Once a fault is detected, the corresponding protective functions will be activated. The following faults are displayed on the AC drive digital keypad. The six most recent faults can be read on the digital keypad display by viewing Pr.6-07 to Pr.6-12.

NOTE: faults can be cleared by pressing the Reset key on the keypad or Input Terminal.

### Common Problems and Solutions:

| Fault Name | Fault Descriptions   | Corrective Actions  |
|------------|--|---|
| OC         | The AC drive detects an abnormal increase in current.                                  | <ul style="list-style-type: none"> <li>. Check whether the motor's horsepower corresponds to the AC drive output power.</li> <li>. Check the wiring connections between the AC drive and motor for possible short circuits</li> <li>. Increase the Acceleration time (Pr.1-09, Pr.1-11).</li> <li>. Check for possible excessive loading conditions at the motor.</li> <li>. If there are any abnormal conditions when operating the AC drive after the short-circuit is removed, the drive should be sent back to manufacturer.</li> </ul> |
| OV         | The AC drive detects that the DC bus voltage has exceeded its maximum allowable value. | <ul style="list-style-type: none"> <li>. Check whether the input voltage falls within the rated AC drive input voltage.</li> <li>. Check for possible voltage transients.</li> <li>. Bus over-voltage may also be caused by motor regeneration. Increase the decel time</li> </ul>  |
| OH         | The AC drive temperature sensor detects excessive heat.                                | <ul style="list-style-type: none"> <li>. Ensure that the ambient temperature falls within the specified temperature range.</li> <li>. Make sure that the ventilation holes are not obstructed.</li> <li>. Remove any foreign objects on the heat sink and check for possible dirty heat-sink fins.</li> <li>. Provide enough spacing for adequate ventilation.</li> </ul>   |
| UV         | The AC drive detects that the DC bus voltage has fallen below its minimum value.       | Check whether the input voltage falls within the rated AC drive's input voltage.  |
| OL1        | Internal electronic overload trip  | <ul style="list-style-type: none"> <li>. Check for possible motor overload.</li> <li>. Check electronic thermal overload setting.</li> <li>. Increase motor capacity.</li> <li>. Reduce the current level so that the drive output current does not exceed the value set by the Motor Rated Current Pr.7-00.</li> </ul>   |
| EF         | The external terminal EF-GND goes from OFF to ON.                                      | When external terminal EF-GND is closed, the output will be turned off. (under N.O., E.F.)  |
| OL2        | Motor overload. Check the parameter settings ( Pr.6-03 to Pr.6-05)                     | <ul style="list-style-type: none"> <li>. Reduce the motor load.</li> <li>. Adjust the over-torque detection setting to an appropriate setting.</li> </ul>   |

| Fault Nam   | Fault Descriptions  | Corrective Actions  |
|-------------|---|---|
| <i>ocR</i>  | Over-current during acceleration:<br><ul style="list-style-type: none"> <li>. Short-circuit at motor output.</li> <li>. Torque boost too high.</li> <li>. Acceleration time too short.</li> <li>. AC drive output capacity is too small.</li> </ul> | <ul style="list-style-type: none"> <li>. Check for possible poor insulation at the output line.</li> <li>. Decrease the torque boost setting in Pr.7-02</li> <li>. Increase the acceleration time.</li> <li>. Replace with the AC drive with one that has higher output capacity (next HP size).</li> </ul>                     |
| <i>ocd</i>  | Over-current during deceleration:<br><ul style="list-style-type: none"> <li>. Short-circuit at motor output.</li> <li>. Deceleration time too short.</li> <li>. AC drive output capacity is too small.</li> </ul>                                   | <ul style="list-style-type: none"> <li>. Check for possible poor insulation at the output line.</li> <li>. Increase the deceleration time.</li> <li>. Replace with the AC drive with one that has higher output capacity (next HP size).</li> </ul>   |
| <i>ocn</i>  | Over-current during steady state operation:<br><ul style="list-style-type: none"> <li>. Short-circuit at motor output.</li> <li>. Sudden increase in motor loading.</li> <li>. AC drive output capacity is too small.</li> </ul>                    | <ul style="list-style-type: none"> <li>. Check for possible poor insulation at the output line.</li> <li>. Check for possible motor stall.</li> <li>. Replace with the AC drive with one that has higher output capacity (next HP size).</li> </ul>   |
| <i>cf1</i>  | Internal memory IC can not be programmed.   | <ul style="list-style-type: none"> <li>. Switch off power supply.</li> <li>. Check whether the input voltage falls within the rated AC drive input voltage.</li> <li>. Switch the AC drive back on.</li> </ul>  |
| <i>cf2</i>  | Internal memory IC can not be read.   | <ul style="list-style-type: none"> <li>. Check the connections between the main control board and the power board.</li> <li>. Reset drive to factory defaults.</li> </ul>   |
| <i>cf3</i>  | Drive's internal circuitry abnormal.  | <ul style="list-style-type: none"> <li>. Switch off power supply.</li> <li>. Check whether the input voltage falls within the rated AC drive input voltage. Switch on the AC drive.</li> </ul>  |
| <i>HPF</i>  | Hardware protection failure   | Return to the factory.  |
| <i>code</i> | Software protection failure   | Return to the factory.  |
| <i>cfR</i>  | Auto accel/decel failure  | Don't use the function of auto acceleration/ deceleration.  |
| <i>CE1</i>  | Communication Error   | <ul style="list-style-type: none"> <li>. Check the connection between the AC drive and computer for loose wires.</li> <li>. Check if the communication protocol is properly set.</li> </ul>   |
| <i>bb</i>   | External Base Block.<br>AC drive output is turned off.  | <ul style="list-style-type: none"> <li>. When the external input terminal (B.B) is active, the AC drive output will be turned off.</li> <li>. Disable this connection and the AC drive will begin to work again.</li> </ul>   |
| <i>ol</i>   | The AC drive detects excessive drive output current.  | <ul style="list-style-type: none"> <li>. Check whether the motor is overloaded.</li> <li>. Reduce torque compensation setting as set in Pr.7-02.</li> <li>. Increase the AC drive's output capacity.</li> <li>. <b>Note:</b> The AC drive can withstand up to 150% of the rated current for a maximum of 60 seconds.</li> </ul> |

## Standard Specifications

|                              |                              |  |   |     |  |
|------------------------------|------------------------------|--|---|-----|--|
| Voltage Class                |                              | 220V   |   |     |  |
| Model Number SE-2 □□□ 1A     |                              | 002  | 004   | 007 |  |
| Applicable Motor Output (kW) |                              | 0.2  | 0.4   | 0.7 |  |
| Output Rating                | Rated Output Capacity (kVA)  | 0.6  | 1.0   | 1.6 |  |
|                              | Rated Output Current (A)     | 1.6  | 2.5   | 4.2 |  |
|                              | Max. Output Voltage (V)      | Three-phase corresponds to input voltage   |   |     |  |
|                              | Rated Frequency (Hz)         | 1.0~400Hz  |   |     |  |
| Power                        | Rated Input Current (A)      | 4.9  | 6.5   | 9.7 |  |
|                              | Input voltage Tolerance      | Single phase 200~240V 50/60Hz  |   |     |  |
|                              | Frequency tolerance          | ±5%  |   |     |  |
| Control Characteristics      | Control system               | SVPWM (Sinusoidal Pulse Width Modulation, carried frequency 3kHz~10kHz)  |   |     |  |
|                              | Output Frequency Resolution  | 0.1Hz  |   |     |  |
|                              | Torque Characteristics       | Including the auto-torque, auto-slip compensation, starting torque can be 150% at 5 Hz   |   |     |  |
|                              | Overload Endurance           | 150% of rated current for 1 minute   |   |     |  |
|                              | Accel/Decel Time             | 0.1~600Sec. (can be set individually)  |   |     |  |
|                              | V/F pattern                  | V/F pattern adjustable   |   |     |  |
|                              | Stall Prevention Level       | 20~200%, setting of Rated Current  |   |     |  |
| Operating Characteristics    | Frequency Setting            | Keypad   | Setting by ▲▼ keys or V.R   |     |  |
|                              |                              | External Signal  | Potentiometer-5k <sup>*</sup> /0.5W, DC 0 ~ +10V (input impedance 47k <sup>*</sup> ), 4~20mA (output impedance 250 <sup>*</sup> ), multi-function inputs 1 to 3 (3steps, JOG, UP/DOWN command), communication setting |     |  |
|                              | Operation Setting            | Keypad   | Setting by RUN/STOP keys  |     |  |
|                              | Signal                       | External Signal  | M0,M1,M2,M3 can be combined to offer various modes of operation, RS-485 communication port  |     |  |
|                              | Multi-function Input Signal  | Multi-step selection 0 to 3, Jog, accel/decel inhibit, first/second accel/decel switch, counter, PLC Operation, external Base Block (NC,NO) selection  |   |     |  |
|                              | Multi-function Output Signal | AC Drive Operating, Frequency Attained, Non-zero speed, Base Block, Fault Indication, Local/Remote indication, PLC Operation indication.   |   |     |  |
| Other Function               |                              | AVR, S-curve, Over-Voltage Stall Prevention, DC Braking, Fault Records, Adjustable Carried Frequency, Starting Frequency Setting of DC Braking, Over-Current Stall Prevention, Momentary Power Loss restart, Reverse Inhibition Frequency Limits, Parameter Lock/Reset |   |     |  |
| Protection                   |                              | Over Voltage, Over Current, Under Voltage, Overload, Electronic thermal, Overheating, Self-testing   |   |     |  |
| Other                        |                              | Including EMI Filter   |   |     |  |
| Cooling                      |                              | Forced air-cooling   |   |     |  |
| Environment                  | Installation Location        | Altitude 1,000 m or below, keep from corrosive gasses, liquid and dust   |   |     |  |
|                              | Ambient Temperature          | -10 <sup>*</sup> -40 <sup>*</sup> (Non-Condensing and not frozen)  |   |     |  |
|                              | Storage Temperature          | -20 <sup>*</sup> to 60 <sup>*</sup>  |   |     |  |
|                              | Ambient Humidity             | Below 90%RH (non-condensing)   |   |     |  |
|                              | Vibration                    | 9.80665m/s <sup>2</sup> (1G) less than 20Hz, 5.88m/s <sup>2</sup> (0.6Gat) 20 to 50Hz  |   |     |  |